

The Perfect Naval Weather Sensor

- **5+1 Parameters in one** and at the same time
 - ▷ Wind direction
 - ▷ Wind speed
 - ▷ Air temperature
 - ▷ Air humidity
 - ▷ Barometric pressure
 - ▷ + Dew point temperature (calculated value)
- With independent, integrated sensors for high accuracies of each individual parameter
- Without movable measuring elements, i. e. no abrasion, low maintenance and very easy to service
- For very high wind speeds up to 85 m/s

Applications

- On board of all types of ships (ship meteorology)
- Coastal Surveillance
- Offshore wind turbines
- Industrial and port facilities
- Drilling rigs

Advantages at a Glance

- Extreme robust, compact weather sensors in the high-quality, pollutant-resistant housing made of anodized aluminium
- Integrated heating system for non-icing operation all year round
- Lamella shelter for accurate measurements of the temperature-humidity sensors
- Static-thermal measuring principle for wind parameters with permanent air density compensation for wear-free, reliable measurements
- Standard RS-422 interface with ESD protection
- ASCII data protocol according to NMEA 0183
- Power supply 24 V DC with integrated overvoltage protection
- Simple visualization of the measured values via Meteo-LCD indicators
- Storage, evaluation and display of the measured values by means of evaluation software "MeteoWare CS3"
- Simple, space-saving assembly on 50 mm standard pipe



1 Introduction

The sensors of the EOLOS family are very robust, compact and extremely reliable. When developing these sensors particular consideration has been given to highest quality for fulfilment of meteorological requirements.

The sensors embody the experience of more than 150 years of development and production of LAMBRECHT wind sensors. The system acquires the horizontal air flow and processes the measuring data to the meteorological parameters wind speed and wind direction. Furthermore the weather-module of the EOLOS-NAV2 acquires the meteorological parameters air temperature, relative humidity and barometric pressure. Based on the measured data EOLOS-NAV2 calculates the dew point temperature and provides for its serial output along with the measuring data.

The sensors and further system components are mounted in a splash water- and dust proof metal housing.

The measuring data are automatically transmitted via serial interface RS-422 in talker mode, when power supply is switched on.

Due to their shock- and vibration proof construction the sensor EOLOS-NAV2 is particularly qualified for use under severe environmental conditions. The housing is made of anodized seawater resistant aluminium.

An electronically controlled heating device enables the sensor to operate in between the wide range of -40 up to 70 °C.

1.1 Warranty advices

Please note the loss of warranty and non-liability by unauthorized manipulation of the system. You need a written permission of the LAMBRECHT meteo GmbH for changes of system components. These activities must be operated by a qualified technician.

The warranty does not cover:

1. Mechanical damages caused by external impacts (e. g. icefall, rockfall, vandalism).
2. Impacts or damages caused by over-voltages or electromagnetic fields which are beyond the standards and specifications in the technical data.
3. Damages caused by improper handling, e. g. by wrong tools, incorrect installation, incorrect electrical installation (false polarity) etc.
4. Damages which are caused by using the device beyond the specified operation conditions.

1.2 Advantages of the static measuring principle

The sensor EOLOS-NAV2 is a modern system to carry out precise and reliable measurements under hardest application and environmental conditions. The wind measurements take place according to the principle „TAV“ (thermal aura field variation), i. e. static, without moving parts.

Static measuring principle for wind measurements means:

- Determination of data works without moving measuring elements, i.e. none abrasion, least maintenance and none recalibration because of this method.
- The wind parameter can be measured also in winter time accurate and precise, because of the electronic controlled heating for the immovable measuring elements. This heating is particularly effective against ice and snow in all climatic zones.
- Lightweight mass and immovable measuring elements to enable very low starting values, distance- and attenuation constants as well as a very high repetition accuracy.
- The sensor rapidly can be installed. Due to the special measuring principle minor changes from the angle of pitch can be disregarded.

Advantages of the sensor:

- Apart from the sensors for wind speed and direction the compact housing also contains built-in sensors for air temperature, relative humidity and barometric pressure.
- The built-in test function of the station, enabled by the tight integration of the meteorological sensors into the enclosure, can perform cyclic self-testing and notify the user of erroneous data or failure.
- The compact design of this sensor with 5 meteorological parameters is eliminating the traditional cabling and installation work significantly. Distribution boxes, power supply units and other accessories can be reduced to a minimum expense.

2 Setting to work

Wind can be represented by a vector quantity. For a complete description of the wind it is necessary to specify its speed and direction. The two components are subject to spatial and temporal variations; thus, strictly speaking, they are valid only for the site where the measuring instrument is installed. We therefore recommend selecting the place of installation very carefully.

2.1 Installation conditions

2.1.1 Generally

For professional wind measurements according to meteorological standards (e. g. VDI 3786, Part 2) location and height of the wind sensor are important for representative and accurate results. Generally, wind measuring instruments should not measure the specific wind conditions of a limited area, but indicate the typical wind conditions of a wider area. To obtain results which are representative for a wider area and comparable to values measured at different places, the sensor must not be mounted under the lee of higher obstacles. The distance to any obstacle should be at least 10 times the obstacle's height (corresponding to the definition of an undisturbed area). In general a measuring height of 10 m above ground is regarded ideal.

If an undisturbed terrain of this kind does not exist the sensor have to be put up at an height of at least 6 m above the obstacle height.

If the above mentioned requirements are not feasible e. g. on mobile measurements at vehicles or at measuring containers compromises have to be found and documented.

If the sensor must be installed on a roof top the place of installation must be in the middle of the roof to avoid predominant wind directions. If you want to measure both wind direction and wind speed, it is recommended to mount both sensors at the same spot, where any interaction between the sensors should be avoided. The sensor EOLOS-NAV2 easily meets this requirement.



The place of installation should not be in the operation fields of radar devices (radar scanners or radar transmitters), generators or antennas. We recommend a minimum distance of 2 m to these installations. Furthermore a minimum distance of 5 m to MF-/ HF- and Satcom- (e. g. Inmatsat, VSat) antennas has to be kept. The maximum electric field intensity may not exceed 10 V/m (tested according to EMC standard). When indicated a greater distance should be kept.

To avoid possible measurement errors due to heat sources as hot or warm fumes, hot surfaces etc. next to the sensor, the mounting site should be chosen accordingly.

2.2 Tools and installation aids

There are no special tools or materials required for the installation works. All work can be carried out with standard tools available in a regular workshop.

2.3 Unpacking the sensor

The sensor is packed in a separate box, carefully protected against mechanical influences during transport.

Please verify that the following parts and documents are enclosed:

- 1 sensor EOLOS-NAV2
- 1 operating manual

Accessories: (depend on order size, in all cases separately packed)

Connecting cable with plug and core cable ends

2.4 Goods inspection

Please thoroughly check the delivery with regard to completeness and eventual transport damages. In case of eventual claims please contact us in writing immediately.

2.5 Power supply

The sensor requires at the input connector a 24 V nominal DC power source for operation. The sensor-heating has to be supplied with 24 V DC and has a power consumption of 70 W (max. 3 A).

2.5.1 Power input

The power input of the EOLOS reaches its peak in the start-up period (activation phase). The maximum of the power input is 2.5 A. In normal operation the average power input is significantly lower (see table). The power input mainly depends on the flow rate.

Wind speed	Ø Power input
0 m/s	500 mA
5 m/s	650 mA
20 m/s	900 mA
38 m/s	1100 mA

Measured at supply voltage of 24 V DC and 20 °C (without heating)

2.5.2 Protection

Generally it is not necessary to protect the secondary side (24 V DC) of the EOLOS. Normally only the primary side has to be protected. Nevertheless if the supply should be protected especially we recommend using a micro-fuse 3.15 A - medium time-lag.

2.6 Installation procedure (short instruction)

The installation of the sensor involves 3 steps:

- (1) Mounting the cable at the sensor and if necessary draw the cable through the mast.
- (2) Mounting the sensor at the mast, but before tightening the screws you must align the sensor to the North.
- (3) Attaching the cable to the power supply and the signal acquisition system.

2.7 Mounting

The sensor can be installed on a standard pipe with an outer diameter of 50 mm and an inner diameter of maximum 40 mm. Before tightening the two 8 mm-socket screws and attaching the sensor you have to draw the cable through the pipe and align the sensor into driving direction.

For this purpose the housing is marked accordingly (see drawing). Before the screws of the sensor are tightened, the sensor is adjusted to North. Please pay attention to a firm mounting of the sensor at the mast!

In addition the sensor has a pin for the north direction. You can put this pin into the nick at the mast (if available). If needed you can turn in or unscrew the pin by means of allen key.

2.7.1 North alignment of wind sensor

For wind direction measurements the north mark on the sensor must be aligned with the geographical north direction.

To adjust the wind sensor in a firm and correct manner into the north direction this item is equipped with an integrated mounting aid. Inside the inner bottom of the sensor a small bolt pointing to the North is integrated to be set into a corresponding slot of the mounting pipe (if available). Thus the sensor is safely attached. If needed you can turn in or unscrew the pin by means of allen key.

To set up the sensor's north orientation select a landmark which is as far as possible up north with regard to the final position of the wind direction sensor.

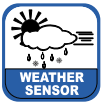

The reference point can be selected using a topographical map (1:25000). The exact position of the reference point is determined using an amplitude compass that can be adjusted horizontally on a stand.



Compass declination has to be considered!

To align the sensor ahead (on ships) locate a point outside the ship in the landscape which is located in the ship ahead direction respectively in the centre line or in case of the sensor is mounted far away from the middle line a line parallel to the centre line.

Once the sensor is adjusted, it can be fixed with the two hexagonal screws. Finally the earth screw has to be connected to the ship's ground. Acid-free contact grease is recommended to protect contact surfaces against corrosion.



Note: Follow all safety instructions while setting up the sensor onto a mast.

2.7.2 Power and signal connection

The EOLOS-NAV2 sensor requires a 12-pole bayonet plug connector. The cable shield should be connected with both ends at the ground wire (PE).



To reduce the risk of inductive interference the sensor must be properly grounded (screening on both sides).

The external connection is via central connector which is located in housing base. For further details about electrical connection please see chapter „Connecting diagrams“.

If the sensor is mounted in correct manner and connected with the right cable (accessory), you can attach the wires to power supply and signal outputs to data acquisition equipment (computer).

The typical power supply requirements of the EOLOS-NAV2 sensor are 24 Volts with a maximum current drain of 2.5 A. The input range is max. 18...32 V DC. The heater of the EOLOS-NAV2 is to supplied with 24 V DC and has a heating power of 70 W (max. 3 A).

The serial digital output of the sensor uses differential line drivers with high common mode noise rejection. The signal levels and timings conform to the requirements of EIA/RS-422 / Talker. The line drivers are capable of transmitting data over cable lengths up to 1,220 meters (4,000 feet). This maximum distance will vary depending upon the operational environment, the wire gauge used, and the baud- rate of the attached devices.

When the power supply of the sensor is switched on, after 30 seconds (in order to reach operating temperature) the sensor cyclically starts sending data protocols.

2.7.3 Safety regulations



Because the wind sensor often is mounted on exposed locations in dangerous heights the installation personnel has to pay attention to the relevant safety regulations for such works. During the electrical installation and termination works the external circuit-breaker must be switched off.

It is not permitted to open those housings by unauthorized persons!

3 Maintenance

3.1 Regular maintenance and calibration

The sensor EOLOS-NAV2 is service reduced and designed for a very long lifetime. Recommended is a regular visual check regarding dirt of surface caused by the weather and if so, to clean up.



If reference measurements should be necessary stringently must be noted that a comparability of the measured values is given only if the measurements take place under same conditions. I.e. the reference equipment must be used very close to the sensor!

The sensor is a measuring instrument and thus apply user specific standards regarding period of recalibration.

Recommendation: 2 years.

We recommend to have the filter cap of the humidity-temperature sensor every two years exchanged in our plant. Depending on the application shorter maintenance cycles could be necessary.

3.2 Visual check and cleaning

The use of the sensor under the respective environmental conditions requires certain steps. It is thus recommendable to clean the outside of the housing and shelter within specific intervals. The intervals are dependant on the environmental conditions and the degree of soiling. We recommend a regular sight and functional check.

In case you should be faced with any specific problems please contact the LAMBRECHT meteo service under:

Tel.: +49-(0)551-4958-0

Fax: +49-(0)551-4958-312

E-Mail: support@lambrecht.net

4 Transports

In case it is necessary to ship or to transport the sensor must be carefully packed to prevent damages during transport.

5 Illustrated part catalogue

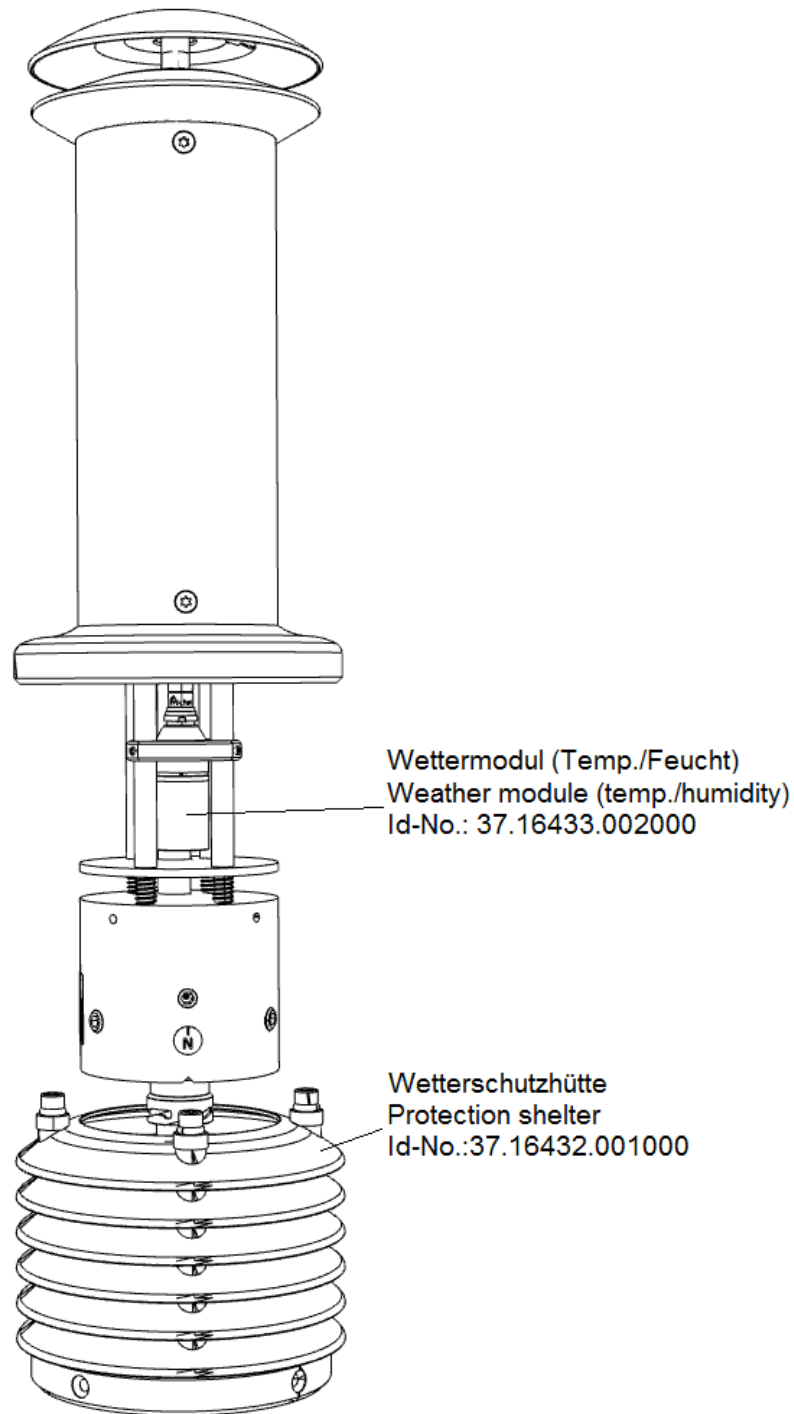

Figure:
Spare parts and
consumables

Spare parts list

No.	Description	Part no.	Qty per unit
1	Protection shelter with lamellas	37.16432.001000	1
2	Weather module (TH)	37.16433.002000	1
3	Sinter cap weather module	37.08095.100001	1

6 Dismantling and assembling of the lower sensor part

To get access to the sensor elements for temperature, relative humidity and air pressure the protection shelter and lamellae have to be dismantled.

Tools:

- Hex-wrench 1.5
- Hex-wrench 4.0
- Hex-wrench 5.0
- Torx wrench with TX20 impulse
- LOCTITE mounting glue no. 274

Dismantling of protection shelter

- (1) Remove of earthing connection screw with hex-wrench 5.0.

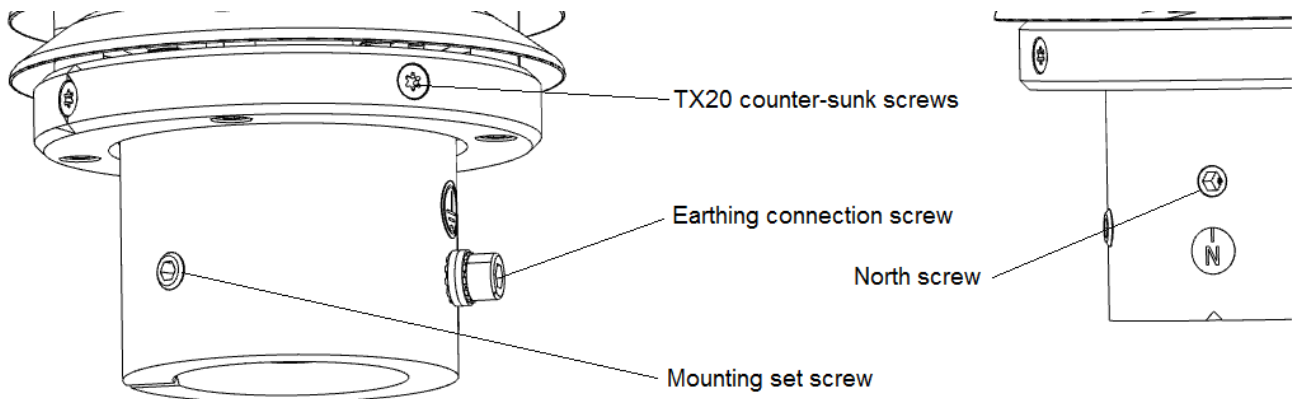

- (2) Unscrew the mounting set screws and the North screw with hex-wrench 4.0 and assemble them at that they protrude from the sensor foot.

- (3) Unscrew the 4 counter-sunk screws from the lower ring of the protection shelter with torx wrench TX20.

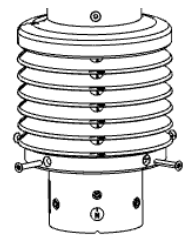

- (4) Pull down the protection shelter carefully and take it off.

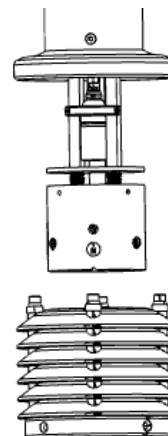

Dismantling of weather module

- (5) After the protection shelter was dismantled the weather module can be removed and exchanged.
 - (6) Unscrew the set screws at the sensor stabilisation of the protection shelter with hex-wrench 1.5.
 - (7) Move the sensor stabilisation upwards (maybe fix it by slight screwing of a cylindrical screw).
 - (8) Grab the weather module at the detach ring of the plug lock with thumb and forefinger.
 - (9) Push down the spring-loaded protection plate (white) and dismantle the weather module.
- Note:** The weather module can only be detached by grabbing the detach ring.
- (10) Remove the weather module by tilting it out sideways. At the same time hold the protective plate (white) down.

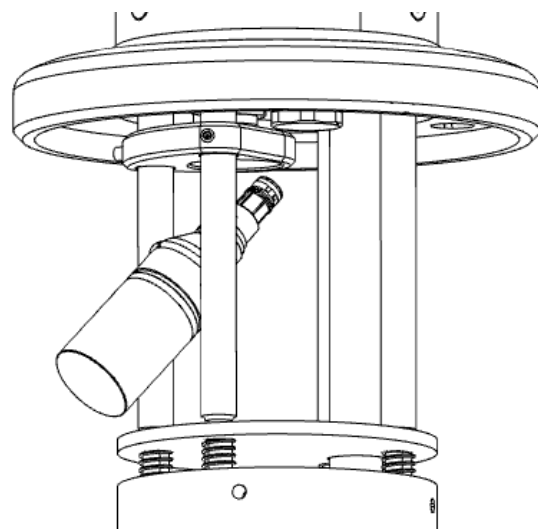
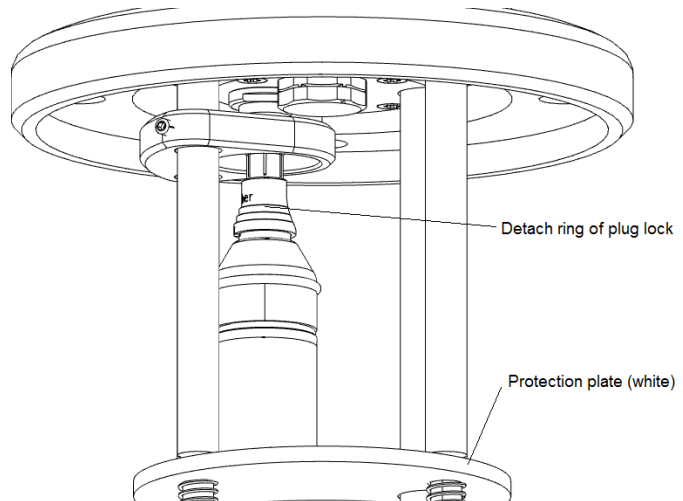
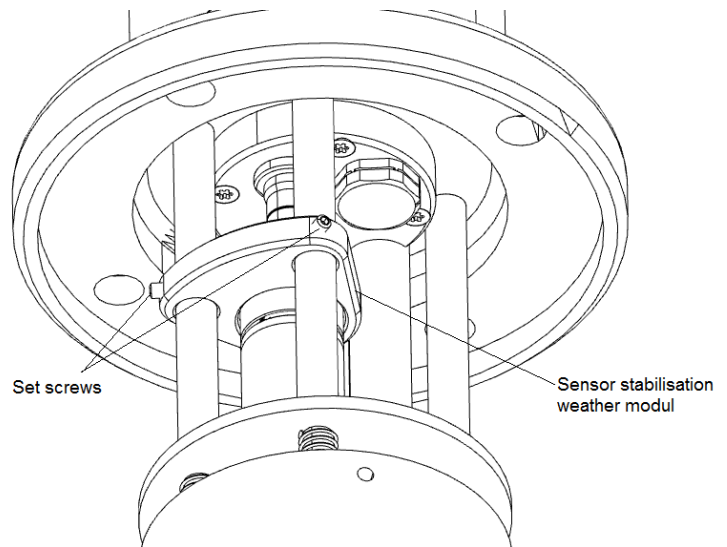

After this the sinter cap of the weather module can be cleaned. For this unscrew the sinter cap carefully from weather module. The sinter cap can be cleaned in an ultrasonic bath or with water and a mild detergent. After cleaning the sinter cap should be washed up with clear water. Before it will be screwed on the weather module it has to be completely dried. We suggest working with an exchange cap to assure that the weather module isn't unprotected for too long.

Assembly of the sensor

Installation of the weather module

- (1) Sideway insertion of the weather module in sensor stabilisation. For this push the protection plate (white) down continuously.
- (2) The point marking of the module plug and the sleeve shall be coincided and the weather module shall be plugged in until it makes "CLICK".
- (3) Pull the sensor stabilisation again onto the weather module that the O-ring of the weather module is in the middle of the sensor stabilisation (maybe unscrew set screw before).
- (4) Fix set screws (hex-wrench 4) of the sensor stabilisation.

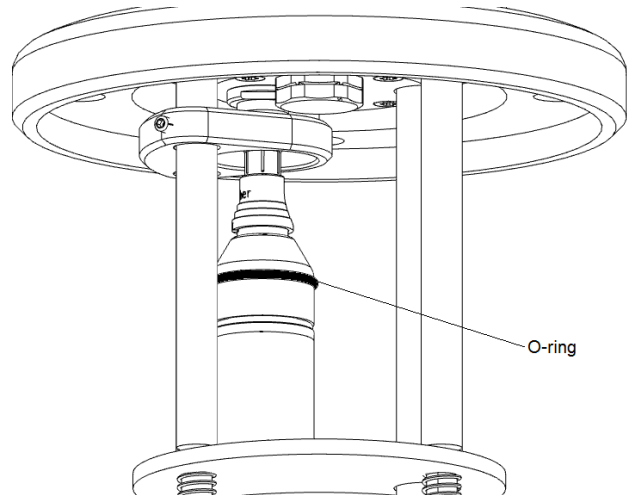
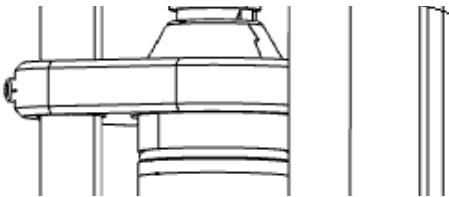
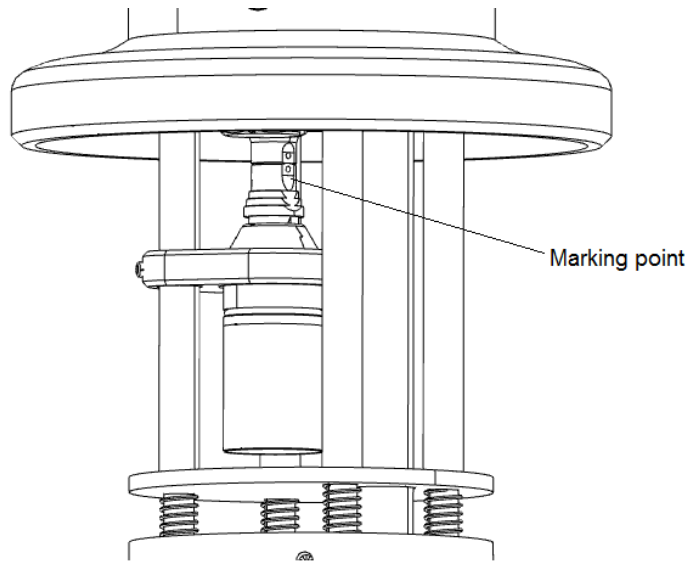

- (5) Push the protection shelter from downwards onto the sensor. Please note that the upper heads of the cylindrical head screws are fixed in the appropriate pilot holes.
- (6) Fix the protection shelters with 4 TX20 counter-sunk screws.
- (7) Screw the mounting set screws and the north screw as far as the sensor can be placed on the mast.
- (8) Fix the earthing screws.

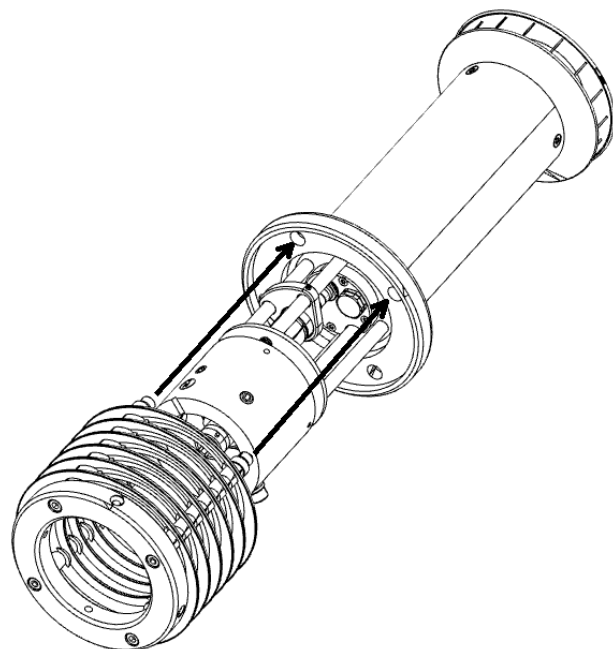

7 Dimensional drawings and electrical connections EOLOS-NAV2

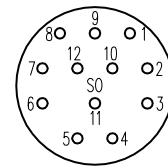
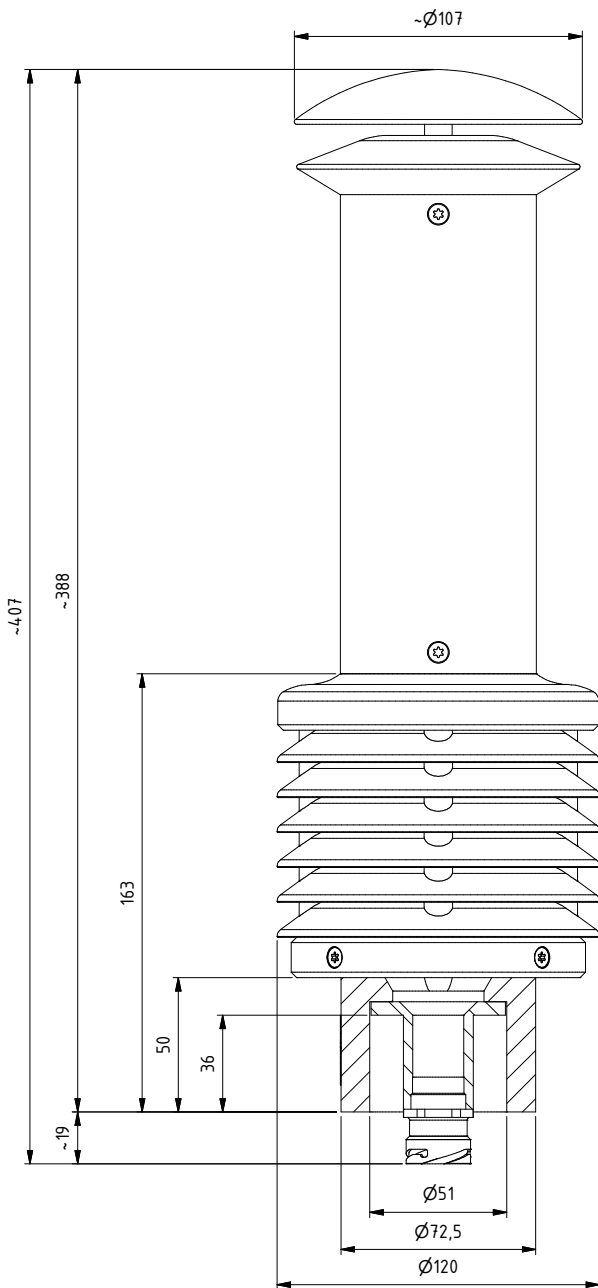

Steckerbelegung
pin assignment

AWG-cable colorcode	
1	blk-black
2	brn-brown
3	red-red
4	ora-orange
5	yel-yellow
6	grn-green
7	blu-blue
8	vio-violet

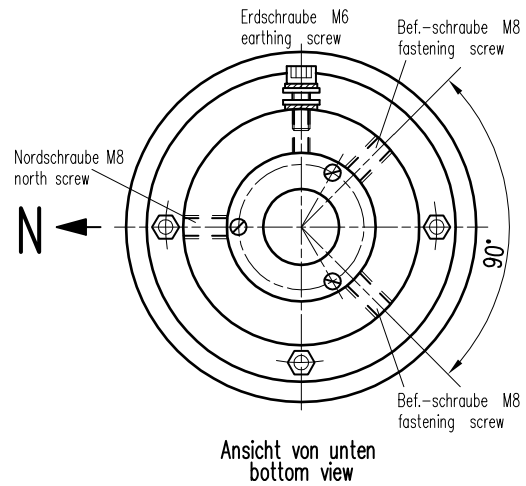
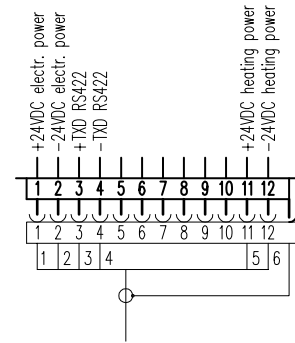

Bei exaktem Mastende von $\varnothing 50,9$ mm ist die Befestigung vibrationsgeprüft.

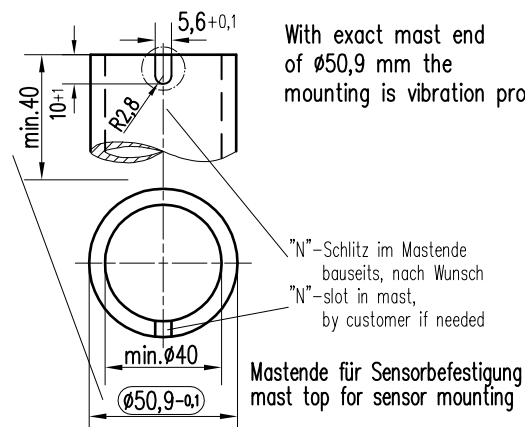
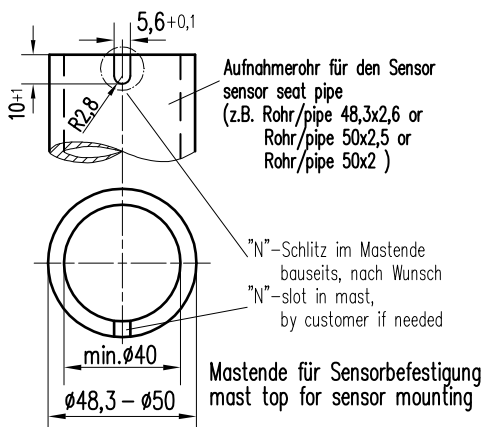

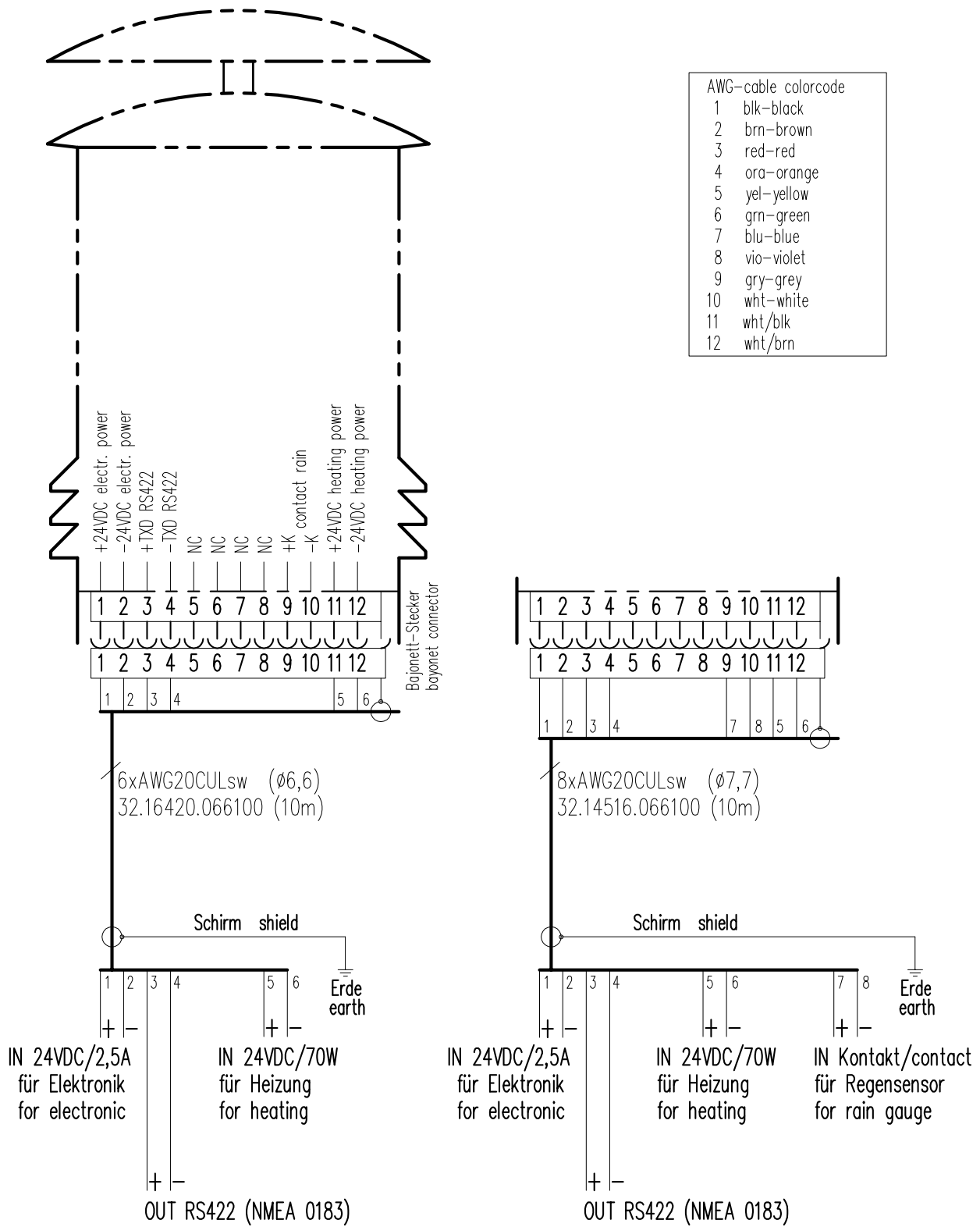

AWG-cable colorcode	
1	blk-black
2	brn-brown
3	red-red
4	ora-orange
5	yel-yellow
6	grn-green
7	blu-blue
8	vio-violet
9	gry-grey
10	wht-white
11	wht/blk
12	wht/brn



8 Data protocols EOLOS-NAV2

Wind direction and wind speed

Example of data sequence with comma separated fields: \$WIMWV,357.0,R,5.2,M,A*CS<CR><LF>

field delimiter: , (comma)

header: \$WIMWV

wind direction: 0.0...360.0

R: relative wind direction

wind speed: 0.1...85.0

M metric units m/s

status A (valid) / V (not valid)

stop delimiters: <CR> <LF>

error code: WD 999.9

error code: WS 999.9

Message string WIMTA air temperature

Example of data sequence with comma separated fields: \$WIMTA,-25.0,C*CS<CR><LF>

field delimiter: , (comma)

header: \$WIMTA

temperature: -40.0...+70.0

C: °C

stop limiters: <CR> <LF>

error code: 999.9

Message string WIMMB barometric pressure

Example of data sequence with comma separated fields: \$WIMMB,,,1050.0,B*CS<CR><LF>

field delimiter: , (comma)

header: \$WIMMB

barometric pressure: 600.0...1100.0

B: air pressure in hPa

stop limiters: <CR> <LF>

error code: 9999.9

Message string WIMHU relative humidity

Example of data sequence with comma separated fields: \$WIMHU,100.0,-40.0,C*CS<CR><LF>

field delimiter: , (comma)

header: \$WIMHU

rel. humidity: 000.0...100.0

dew point temp.: -40.0...+70.0

C: °C

stop limiters: <CR> <LF>

error code: 999.9

Important! Please note:

Field length

The development of a NMEA decoder should not be proceeded from firm field lengths. The NMEA definition proceeds from a variable field length. The comma character (",") serves as field disconnecting switch. Numeric values in a field can be presented differently. In case a field is not sent, it has a length of 0 characters (,,) [comma-comma].

Check sum

The check sum "CS" is covered to two ASCII characters hexadecimal value. "CS" calculated by XOR operation of each character in the sentence between "\$" and "*", but excluding "\$" and "*".

Error code

In case, that the sensor cannot generate a measuring value because e.g. a sensor element is defect or implausible (raw) values are collected the sensor outputs in the corresponding data protocol the above mentioned error code (e.g. 999.9) and sets the status from "A" (valid) to "V" (not valid).

Example: \$WIMWV,999.9,R,999.9,M,V*0E<CR><LF>

Particular characteristics wind direction value

Theoretically the value for the wind direction can take any value between 0.0° and 360.0°. It should be noted, that in a full circle the values "0.0" and "360.0" are describing the same direction. According to the international valid recommendations of the WMO (World Meteorological Organization) in the "Guide to Meteorological Instruments and Methods of Observation" (WMO-No.8) the wind direction value 0.0° just has to be output at calm. The EOLOS follows the recommendation of the WMO and outputs at wind from the north the value "360.0" respectively "0.0" at calm (lull).



9 Versions and technical data

(16432) Static Weather Sensor EOLOS-NAV2

Id-No. 00.16432.210002

Range of application: Temperature -40...+70 °C
wind speed 0...100 m/s
rel. humidity 0...100 % r. h.

Parameters:

Wind direction

Measuring range: 0...360°
Accuracy (RMS): ± 3°
Resolution: 1°

Wind speed

Measuring range: 0.1...85 m/s
Accuracy (RMS): ± 0.5 m/s ± 5 % of the meas. value
Resolution: 0.1 m/s

Temperature

Measuring range: -40...+70 °C
Accuracy: ± 0.8 °C (v > 2 m/s) ¹⁾
Resolution: 0.1 °C

Relative humidity

Measuring range: 0...100 % r. h.
Accuracy: ± 3 % (10...90 %) r. h. ²⁾³⁾
± 4 % (0...100 %) r. h.
Resolution: 0.5 % r. h.

Barometric pressure

Measuring range: 600...1100 hPa
Accuracy: ± 2 hPa (-40...+85 °C) · ± 0,5 hPa at 25 °C
Resolution: 0.1 hPa

Protocols: NNMEA 0183 • WIMWV • WIMHU • WIMMB • WIMTA
Supply voltage: 18...32 V DC⁴⁾ · max. 2.5 A heating:
24 V DC/ 70 W (max. 3 A) · electr. controlled
Housing: Aluminium · anodized · IP 66
Dimensions: H 388 mm · Ø 120 mm · mast adapter
Ø 50 mm for mounting on standard pipe
Weight: Approx. 2.5 kg
Interface: Serial · RS-422/ talker • baud rate 4800
1 Hz (meas. cycle of 4 Hz) • 8 N 1

Standards

- NMEA 0183
- Standard of construction: VDE 0100
- Low voltage guide line: 72/23 EWG
- EMC/ EMI: DIN EN 60945 and DIN EN 61000-4-2, 3, 4, 6, 11
- Salt fog: EN 60945
- Protection class: DIN EN 60529
- Vibration: BV 0240

- ¹ Temperature influence of the shelter: accuracy +1.5 °C at v < 2 m/s and intensive solar radiation
² Temperature influence of the shelter: ± < 0.1 % r.h. at +10...+40 °C
³ Shelter inaccuracy: < 4 % r.h. dependant on v > 2 m/s and solar radiation
⁴ at sensor connector; when connected to a Lambrecht standard cable (15 m) the supply voltage range on the side of the power supply switches to 18.7...32 V DC. When using other cables and cable lengths the individual voltage drop has to be considered.

Accessories: (please order separately)

32.16420.066100 Sensor cable, 10 m,
12 pole bayonet plug

Options: (please order separately)

36.09340.000000 Visualization and evaluation software
MeteoWare-CS3
00.95800.010000 Data logger met[LOG]
00.14742.301002 Display unit METEO-LCD/NAV

10 Disposal

LAMBRECHT meteo GmbH is listed and registered at the Stiftung Elektro-Altgeräte Register ear under:

WEEE-Reg.-No. DE 45445814

In the category of monitoring and control instruments, device type: "Monitoring and control instruments for exclusively commercial use".

Within the EU



The device has to be disposed according to the European Directives 2002/96/EC and 2003/108/EC (Waste Electrical and Electronic Equipment). Do not dispose the old device in the household waste! For an environmentally friendly recycling and disposal of your old device, contact a certified disposal company for electronic waste.

Outside the EU

Please follow the regulations in your country regarding the appropriate disposal of waste electronic equipment.



Quality System certified by DQS according to
DIN EN ISO 9001:2015 Reg. No. 003748 QM15

Subject to change without notice.

EOLOS_NAV2_b-de.indd 47.21

LAMBRECHT meteo GmbH
Friedländer Weg 65-67
37085 Göttingen
Germany

Tel +49-(0)551-4958-0
Fax +49-(0)551-4958-312
E-Mail info@lambrecht.net
Internet www.lambrecht.net