



Features

- ▶ Precipitation sensor for automatic weather stations
- ▶ Linearised pulse output, e. g. for connection to external data loggers
- ▶ Selectable analog output signals, e. g. for easy connection to PLC
- ▶ Selectable measuring ranges as well as absolute or gliding sum for the analogue output signals
- ▶ Exchangeable, weighing tipping bucket system according to Joss-Tognini, overflow proof
- ▶ 2 cm³ tipping bucket (2 g water) for precise precipitation measuring in regions with normal rain falls
- ▶ 4 cm³ tipping bucket (4 g water) for precise precipitation measuring in regions with heavy rain falls / tropical rain
- ▶ Winter-fit model (15189 H analog) with electronically controlled 2-circuit heating
- ▶ Weatherproof materials (anodized aluminium, stainless steel) guarantee a long durability
- ▶ Funnel according to the WMO Standard No. 8



Function

The weighing precipitation sensor (15189 analog) measures the rain quantity by a tipping bucket developed by Joss-Tognini, the bearings of which have been arranged for low friction. Errors that normally occur due to incomplete draining because of surface tension are automatically compensated by the specific form of the tipping bucket.

The tipping bucket can hold 2 cm³ (2 g) resp. 4 cm³ (4 g) of water. The collecting surface of 200 cm² (WMO standard) means that one bucket charge is equivalent to a precipitation rate of 0.1 mm resp. 0.2 mm per square meter.

If the bucket is tipped, the reed contact that is integrated in the sensor will be closed. This signal can be sent as pulse or analog.

The bounce-free, linearised pulse output is permanently available parallel to an analog current or voltage output. Thus an unproblematic integration into a PLC can be carried out.

The analog output can be deactivated for operation in low power mode. In this case the precipitation sensor can be supplied separately from the signal circuit (see fig. 13) or direct via the signal voltage (see fig. 12).

For application in snowfall regions the heated variety (15189 analog) is available for all-year-round measurements. Two separate controlled heating circuits with lowest hysteresis are providing an optimal temperature at which snowing up of the sensor will normally be prevented and evaporation from the heated surfaces will be minimized.

The precipitation sensor (15189 analog) is mounted on a pedestal that is equipped with a connection piece and are attached to a tube with an outside diameter of 60 mm.

The precipitation sensor (15189 analog) is made of weather-resistant aluminium and stainless steel. This assures a long durability.

Dimensional drawing

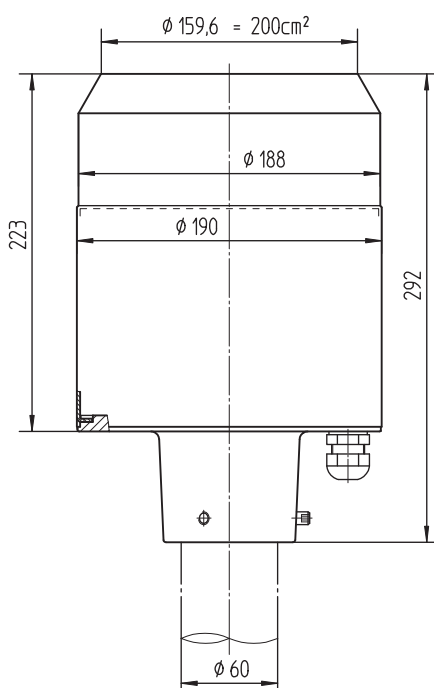

Fig. 0

Installation

Mounting of the sensor

The sensor must be mounted on a tube or pole with an outer diameter of 60 mm. A metallic extension tube with a minimum length of 100 mm is recommended, if a wooden pole is used.

For easy adjustment place a spirit-level on the upper measuring edge.

Attention! Do not damage the measuring edge!

Place the sensor on the end of the pole until it fits in. By using the allen key (4 mm) provided, tighten the screws in the mounting pedestal evenly. Adjust the upper measuring edge to an exact horizontal position. By doing this, the tipping bucket will automatically be positioned vertically inside the device and will work symmetrically to the collecting funnel.

Mounting of the protective covering

When mounting the protective covering, please make sure that the sign "close <-- --> open" (close < - > to) is positioned above the fixing screw. Especially when using the heated version you have to pay attention to this step. This avoids that the cable of the protective covering heating may block the tipping bucket.

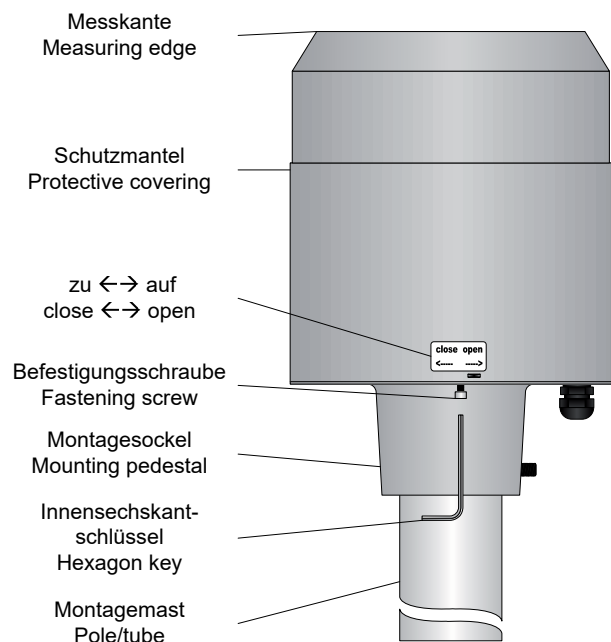

Fig. 1



Attention! In order to protect the tipping bucket the dirt spiral must be inserted in the collection funnel (fig. 2).

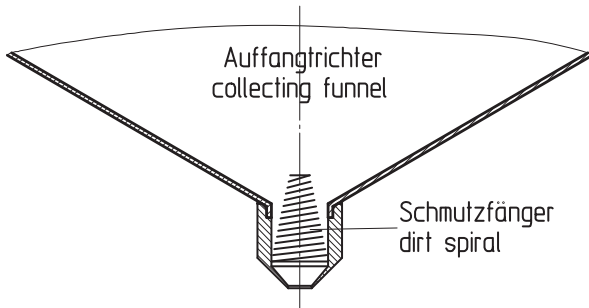
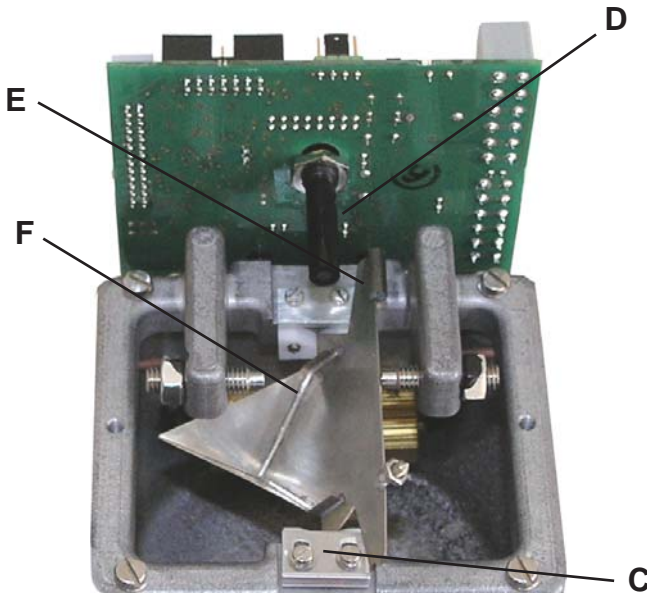

Fig. 2

Dismounting of the protective covering

Loosening the screw (fig. 1) with the provided 3 mm allen key until the protective covering can be turned right to the stop position and take off upward then.



Assembly of the tipping bucket



To avoid damage to the tipping bucket during transport, it is separately packed and should be inserted in the precipitation sensor on site only after mounting the gauge on the mast.

For the assembly first you must remove the protective covering.



Attention! When fitting the tipping bucket, proceed with utmost caution so that the sharp edges of the tipping bucket are not damaged and the middle wall is not bent!

During operation the tipping bucket lies on the precision bucket bearings. To reduce the friction, which is produced at one tipping, the bearings are made of abrasion-resistant delrin.

The mounted tipping bucket is secured against eventual changes of position by means of two plates.

To insert the tipping bucket, first the relocatable locking plate **C** (fig. 3) must be pushed back.

Now insert the tipping bucket **F**. Make sure that the magnet **E** attached at the middle wall of the tipping bucket rests under the capsule with the embedded reed contact **D**.

Finally the tipping bucket must be secured by pushing back the relocatable locking plate **C**.

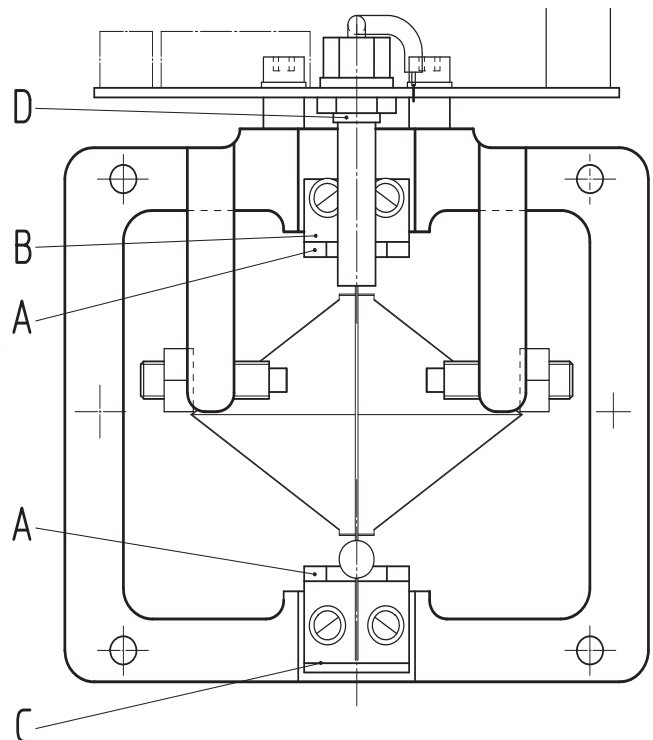

Fig. 3

- A: Tipping bucket bearings
- B: Fixed locking plate
- C: Relocatable locking plate
- D: Reed contact
- E: Magnet (here shown through inclination of the bucket)
- F: Tipping bucket



Electrical connections

The sensor will be connected to the cable by leading the cable through the conduit gland to the connector inside the sensor housing. The recommended cable type is:

(2) (4) x AWG 20 CU L sw;
diameter approx. 5.1 mm

The cable should be not longer than 11 m.



When the cable is transferred inside the soil it is recommended to protect the cable with a protecting plastic tube.

(15189 H analog) Version with heating

The precipitation sensor (15189 H analog) comes with a solid-state-thermostat controlled heating for collecting funnel and drain pipe.

Electrical connections

For the connection of the heating a 2-core cable is required, which has to apply and connected to the power supply unit according to the *connecting diagrams* with heating.

The **function of the heating elements** can be tested also at ambient temperatures above the control temperature of the solid-state thermostat. For this simple test a regular magnet has to be held close to the blue housing of the switching circuit. When reaching a surface temperature of approximately 50 °C the current will be switched off.

Both blue thermostat modules are fitted internally on the funnel surface as well on the bottom of the housing.

The operational conditions will be indicated with colored light-emitting diodes (LED) an the thermostatic module:

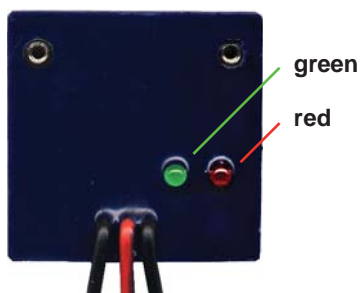

green: supply voltage

red: heating on

Fig. 4

Initial operation

If the sensor system has been completely mounted and electrically assembled, the sensor will be ready for operation according to the sensor settings. The operational check has to be performed.

Maintenance and operational check

The **precipitation sensor (15189 analog)** is nearly maintenance-free. The sensor should be checked and cleaned periodically in order to guarantee its proper operation, since dirt accumulation may cause errors of measurement. The time interval of cleaning depends on the local conditions.

The **operational check** of the sensor may be performed by the use of artificial precipitation. The contents of a 200 cm³ resp. 400 cm³ (by 4 cm³ buckets) test container of water must be conducted into the collecting funnel through a nozzle in such a way that the drops fall into the funnel beside the outlet. The nozzle of the test container (approx. diameter 0.6 mm) should be adjusted to allow a complete water run out into the funnel within 10 to 20 minutes.

After the artificial precipitation has gone through, 100 ± 2 bucket tipplings should have been counted.

Rinse the sensor thoroughly for cleaning. Clinging particles of dirt in the collecting funnel or outlet pipe may be removed with a piece of wood.

If unsatisfying measurement results occur after this cleaning procedure, the tipping bucket should be disassembled for cleaning.



Please take care not to damage the tipping bucket!

The dismantled tipping bucket can be cleaned by placing it in warm water with some scouring material and by carefully scraping off unwanted dirt using a small piece of wood.

Warranty

Please note the loss of warranty and non-liability by unauthorised manipulation of the system. You need a written permission from LAMBRECHT meteo GmbH for changes of system components. These activities must be operated by a qualified technician.

The warranty does not cover:

1. Mechanical damages caused by external impacts (e. g. icefall, rockfall, vandalism).
2. Impacts or damages caused by over-voltages or electromagnetic fields which are beyond the standards and specifications in the technical data.
3. Damages caused by improper handling, e. g. by wrong tools, incorrect installation, incorrect electrical installation (false polarity) etc.
4. Damages which are caused by using the device beyond the specified operation conditions.

Basic settings (Fig. 5)

Unless otherwise agreed the precipitation sensor (15189 analog) will be delivered with following basic settings:

- Active pulse output: linearised • bounce-free signal
- Measuring range: 0...10 mm
- Active analog output: 0...20 mA
- Analog output of the absolute sum of precipitation

- Current consumption: ≤ 40 mA
- Supply voltage: 18...30 V_{DC} • max. load 600 Ω

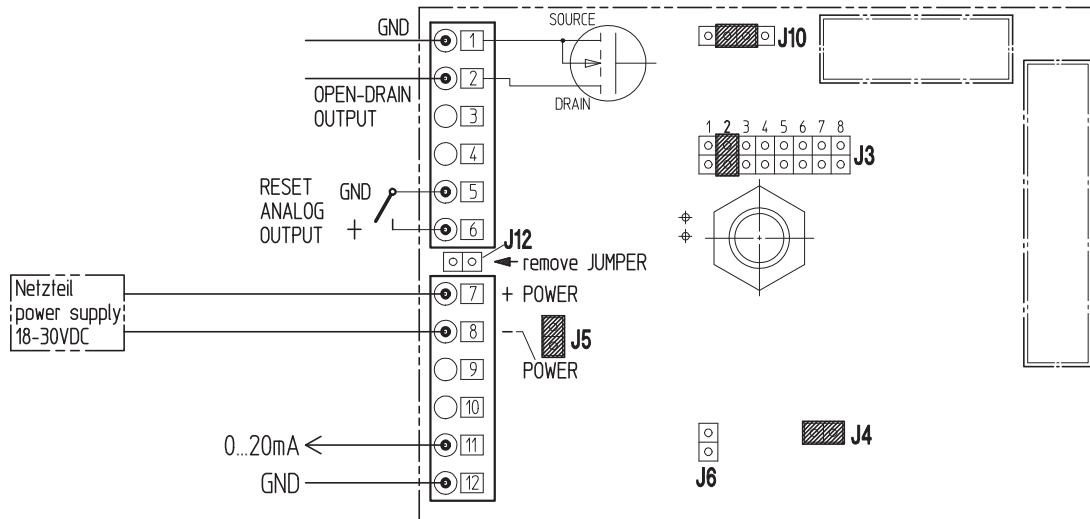

Fig. 5

Connecting diagram with heating

Niederschlags-Sensor
precipitation sensor
00.15189.402050 (2 ccm)
00.15189.404050 (4 ccm)

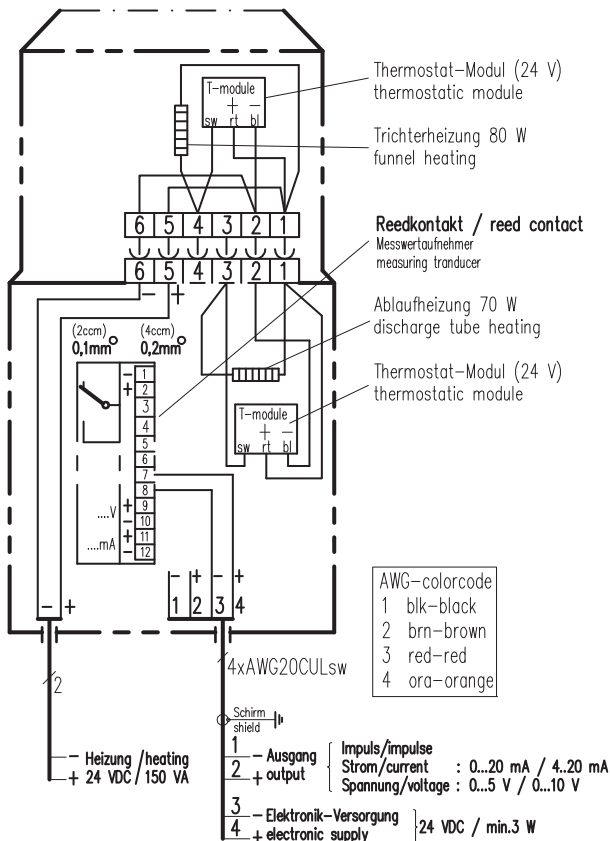

Fig. 6

Connecting diagram without heating

Niederschlags-Sensor
precipitation sensor
00.15189.002050 (2 ccm)
00.15189.004050 (4 ccm)

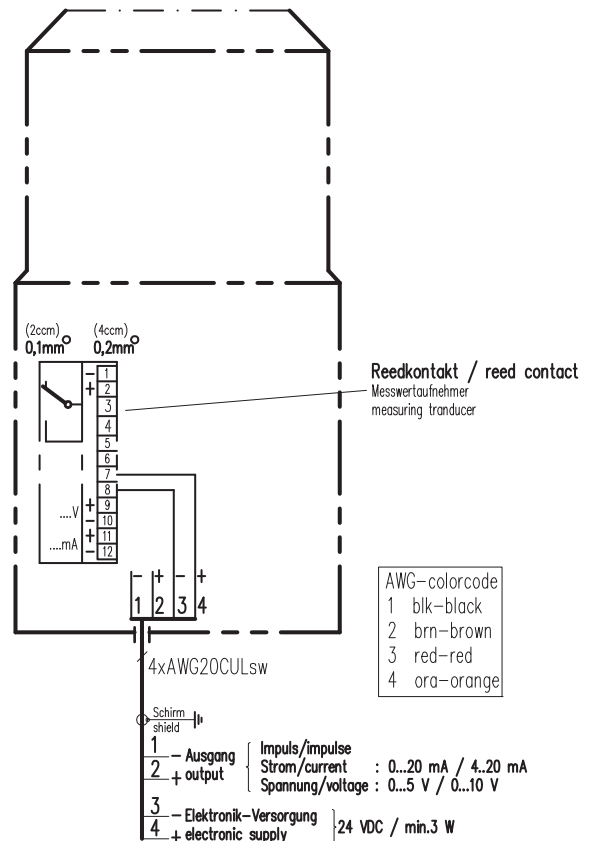

Fig. 7

Further setting options



Changes of the basic settings are urgently allowed in power-off mode. Only if necessary, changes of the basic setting should be carried out by skilled technician.

Changes of settings will be accepted only after reconnecting the power supply. Changes of the jumpers during operation are not allowed.

Please note, changes of the basic settings by users will be carried out on own responsibility. The manufacturer is not liable for consequential damages.

Overview of the selectable operating modes

- 4 analog outputs selectable:
0...20 mA · 4...20 mA · 0...5 V · 0...10 V
- 4 final values of the measuring ranges* for the analog outputs selectable: 10 / 20 / 25 / 50 [mm]
- 4 time-frames of the analog outputs for gliding summation selectable: 1 / 10 / 30 / 60 [minutes]
- 2 modi for low power operation regarding pulse output and power supply selectable

Functions of the jumpers

See also tab. 1:

- **J3** to select the required mode (Pos. 1-8)
- **J4, J5** to switch on the respective analog output
- **J6** to switch over the analog voltage output
- **J12** to connect the switch output to the power supply for 2 wire circuit of the low power modi (not plugged = power supply and pulse output are separated)



- **J10** must be plugged always at the middle position, see fig. 14!

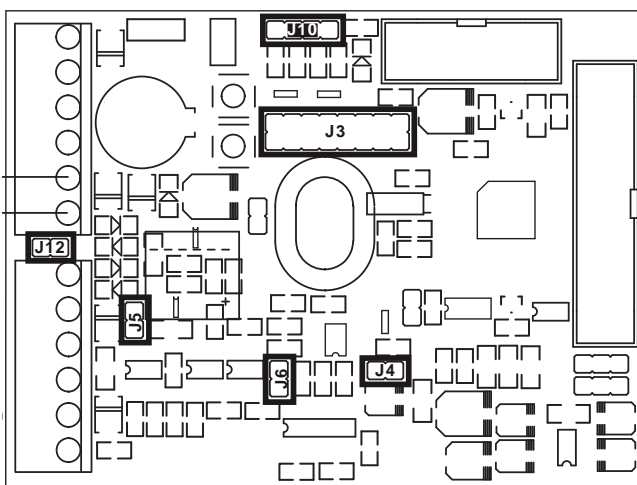

Fig. 8: Positions of the jumpers, which are usable for changes of modi

* These data refer to 2 cm³ volume of tipping bucket.

Mode	J3								J4	J5	J6	J12
	1	2	3	4	5	6	7	8				
0...20 mA							-	-	x	x	-	
4...20 mA							-	x	x	x	-	
0...5 V							x	-	x	x	x	
0...10 V							x	x	x	x	-	
10 mm					-	-			x	x		
20 mm					-	x			x	x		
25 mm					x	-			x	x		
50 mm					x	x			x	x		
1 minute			-	-					x	x		
10 minutes			-	x					x	x		
30 minutes			x	-					x	x		
60 minutes			x	x					x	x		
Low Power, only pulse output separate pulse output	-	-	-	-	-	-	-	-	-	-	-	
Low Power, only pulse output 2 wire circuit	-	-	-	-	-	-	-	-	-	-	-	x
Analog output, absolute sum	-	x							x	x		
Analog output, gliding sum	x	-							x	x		

Tab. 1: Setting options
"x" ... jumper plugged; "-" jumper unplugged

Services:

97.15180.000 000 User-specific configuration of the precipitation sensor

Note: This service is required, if the basic settings of the should be modified by factory.

In principle the changes of the configuration can be carried out on-site by user themselves.

Example 1 (Fig. 9): Active analog output 4...20 mA, otherwise like basic setting

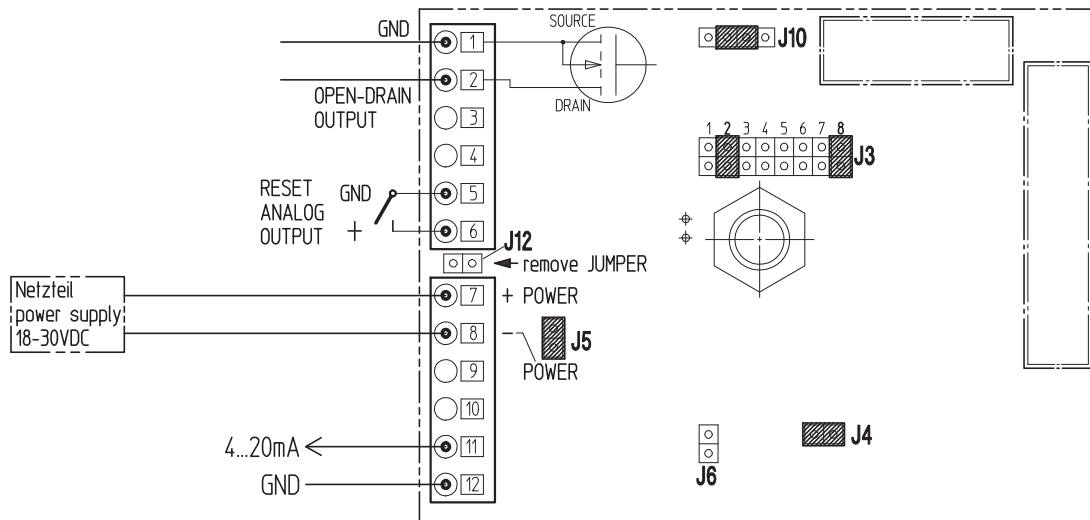

Fig. 9

Example 2 (Fig. 10): Active analog output 0...5 V, otherwise like basic setting

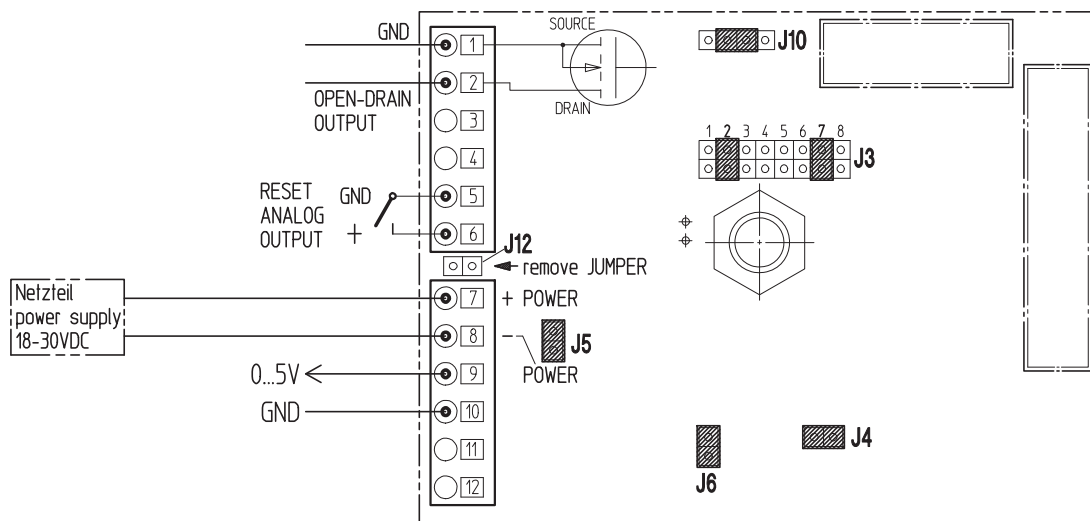

Fig. 10

Example 3 (Fig. 11): Active analog output 0...10 V, otherwise like basic setting

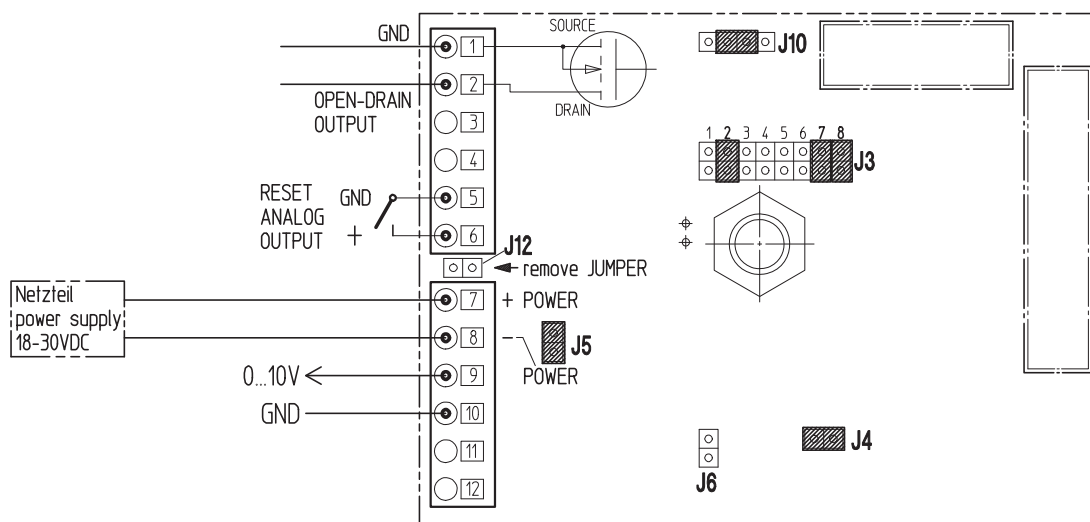

Fig. 11

Example 4 (Fig. 12): Low Power Mode - 2 wire circuit

- Deactivated analog output
- Active pulse output: *linearised • bounce-free signal*
- Current consumpt.: *max. 100 μ A • typical 50 μ m*
- Supply voltage: *5...30 V_{DC}*

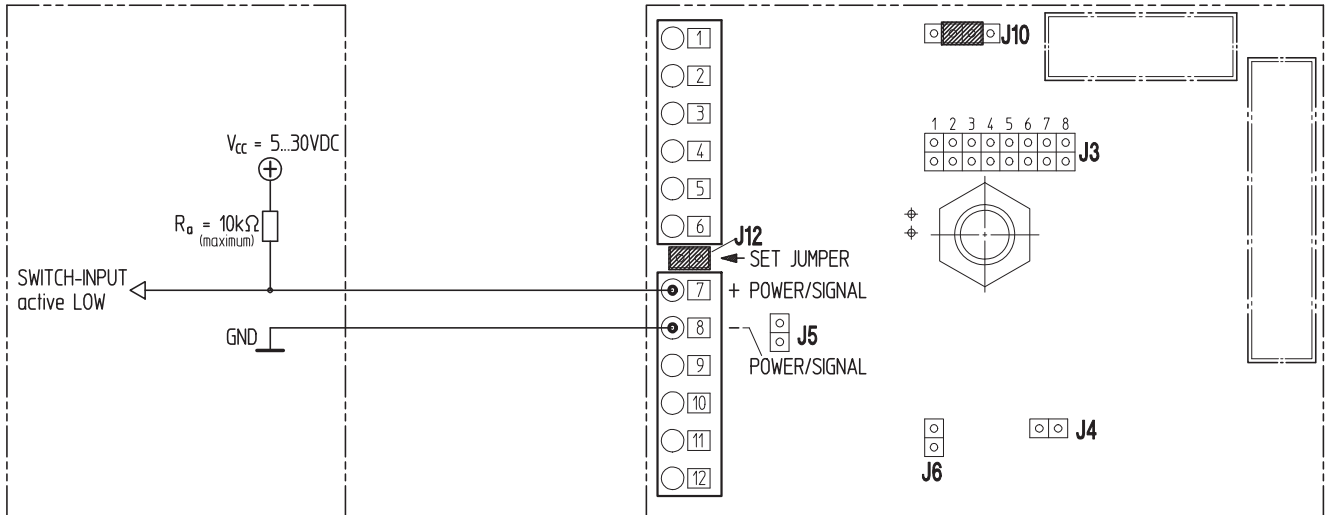

Fig. 12

Example 5 (Fig. 13): Low Power Mode - PLC Interface

- Deactivated analog output
- Active pulse output: *linearised • bounce-free signal*
- Current consumpt.: *max. 100 μ A • typical 50 μ m*
- Supply voltage: *5...30 V_{DC}*

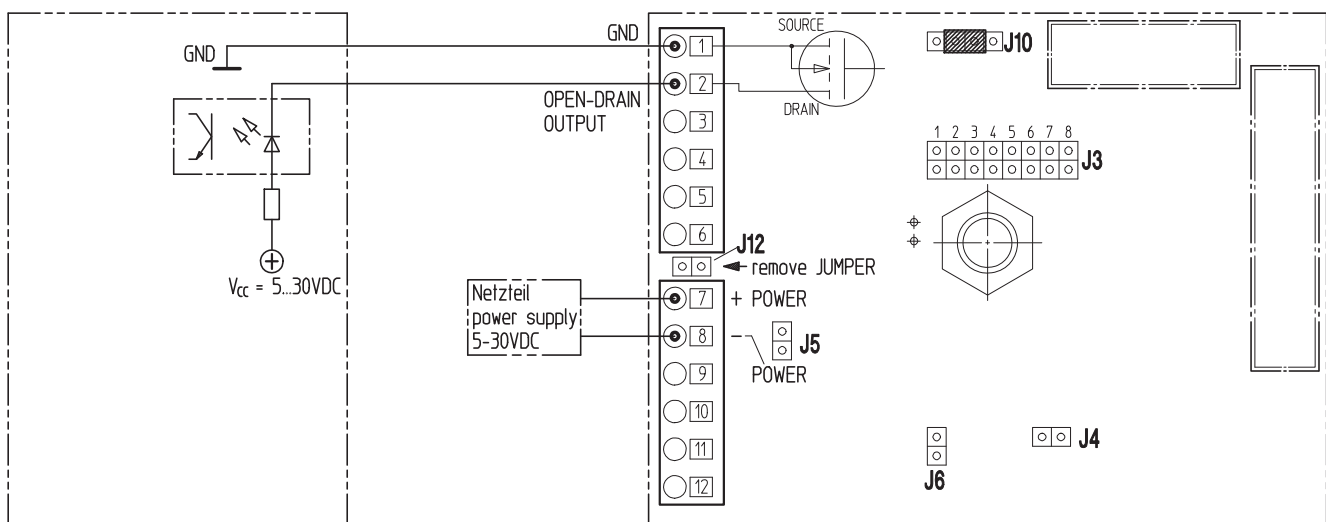

Fig. 13



Explanations of the operating modes

1. Pulse output

The pulse output is permanent activated. The linearised pulses are emitted with a pulse duration of 125 ms. The maximum of output pulses are 100 output signals per minute.



Attention! To avoid damages an additional, current limited resistor of 2...10 kOhm is necessary in that case, when the pulse output is connected to the power supply via jumper J12 (see fig. 12).



The operating mode „2 wire“ is not allowed in combination with analogue output signals.

2. Absolute sum of precipitation

At this operating mode the accumulated amount of precipitation is emitted as analog signal up to the final value of the selected range. At exceeding of this final value a new summation starts, i. e. the analog signal starts again on the low level (sawtooth diagram).

3. Gliding sum of precipitation

At this operating mode the accumulated amount of precipitation, which is updated each minute, is emitted within the selected time-frame. At exceeding the final value of the selected range the analog signal remains on the highest level up to the gliding sum over the adjusted time-frame will be lower than the final value again. This means that the signal is limited and will not reset like the absolute sum.

4. Reset of the analog output signal

By an external switch at the pins "RESET ANALOG OUTPUT" (see fig. 9 to 11) the analog output can be reset to the starting value of the output range.

This means e. g. that at the range of 4...20 mA the output will be reset at 4 mA. The summation starts at zero again.

Blank board (Fig. 14):

Here you can register your specific jumper setting, e. g. for service purposes.

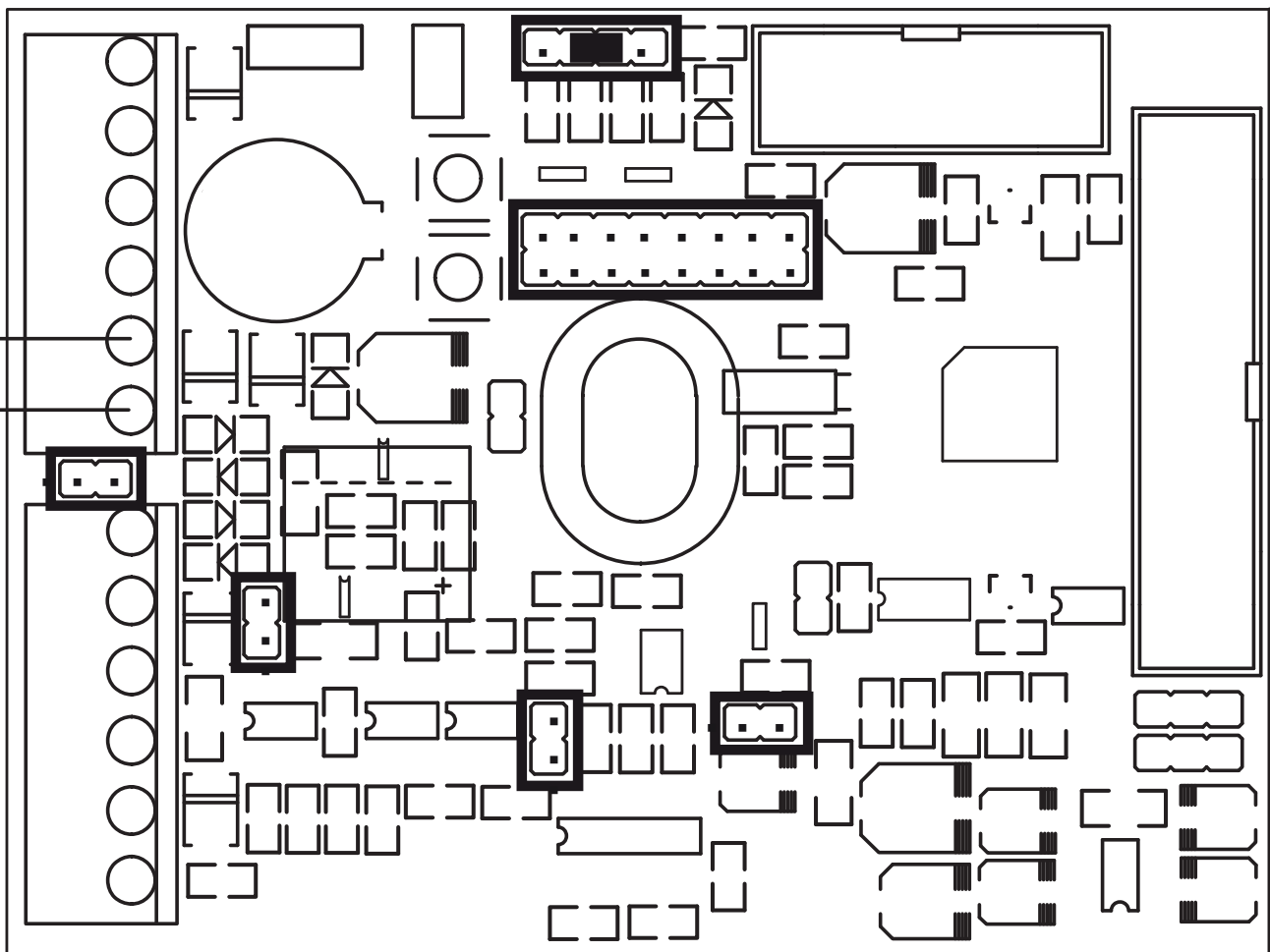

Fig. 14



Technical data

(15189 analog) Version with 2 cm³ bucket, unheated

Id-No. 00.15189.002 050
 Measuring principle: Weighing tipping bucket designed acc. to Joss-Tognini
 Range of application: 0...+70 °C - measuring
 Measuring range: 2 cm³ (2 g water) - volume of bucket
 0...8 mm/min
 Resolution: 0.1 mm
 Accuracy: ± 2 %
 Dimensions: See dimensional drawing
 Suitable for mounting: Ø 60 mm
 Weight: Approx. 4 kg
 Standards: WMO-No. 8 • VDI 3786 Bl. 7
 EN 50081/82 • VDE 0100

Analog outputs: 0...20 mA = basic setting
 4...20 mA • 0...5/10 V - selectable
 Current consump.: ≤ 40 mA
 Supply voltage: 18...30 V_{DC} • max. load 600 Ω

Pulse output for linearised, bounce-free output signal
At deactivated analog output:
 Current consump.: Max. 100 µA • typical 50 µA
 Supply voltage: 5...30 V_{DC}
 Switch load: Max. 30 V_{DC} / max. 0.5 A - at pure ohm load

(15189 W4 analog) Version with 4 cm³ bucket, unheated

Data like (15189 analog), but for very high precipitation intensity
Id-No. 00.15189.004 050
 Measuring range: 4 cm³ (4 g water) - volume of bucket
 0...16 mm/ min
 Resolution: 0.2 mm

(15189 H analog) Version with 2 cm³ bucket, heated

Data like (15189 analog) 00.15189.002 050, but in addition with controlled 2-circuit-heating:
Id-No. 00.15189.402 050
 Heating data: Electronic controlled, dual-circuit
 Accuracy: 4 °C ± 2 °C, controlled temperature within a range of -20...+4 °C
 Heating power: 80 W (funnel)
 70 W (outlet/ tipping bucket)
 Supply voltage: 24 V_{DC} / 150 W
 Range of application: -20...+70 °C (no icing, no snowdrift)

(15189 H W4 analog) Version with 4 cm³ bucket, heated

Data like (15189 W4 analog) 00.15189.004 050, but in addition with controlled 2-circuit-heating, like (15189 H analog)
Id-No. 00.15189.404 050

General accessories:

32.15188.061 090 (15188 U61i) Connecting cable (4-core) sensor/ data logger, L = 7 m
 00.15180.400 000 (1518 S4) Stainless steel mast for concrete foundation
 00.15180.800 000 (1518 S8) Stainless steel mast for concrete foundation with base plate
 32.15180.021 010 (1518 U21a) Bird protection ring
 33.15180.049 000 (1518-49) Dirt spiral (spare part)

For heated versions:

00.14966.200 000 (1496 S62) Power supply unit
 32.15188.061 020 (15188 U61b) Connecting cable sensor/ power supply unit for mounting at the mast; L≈1 m (4-core)
 32.14622.220 000 (14622 S22) Holder for power supply unit on the mast

Services (see page 6):

97.15180.000 000 User-specific configuration of the precipitation sensor

Safety instructions

This system is designed according to the state-of-the-art accepted safety regulations. However, please note the following rules:

1. Before setting into operation, please read all appropriate manuals!
2. Please take notice of internal and state-specific guidelines and/or rules for the prevention of accidents (e.g. the professional association). If necessary ask your responsible safety representative.
3. Use the system according to the manual's regulations only.
4. Always leave the manual at hand at the place of work of the system.
5. Use the system in technically correct conditions only! You have to eliminate influences immediately, which impair the security .
6. Please note the loss of warranty and non-liability by unauthorized manipulation of the system. You need a written permission of the LAMBRECHT meteo GmbH for changes of system components. These activities must be operated by a qualified technician.
7. Prevent the ingress of liquids into the devices without permission.